

DragonFlow

- Integral part of OpenStack
- Fully Open Source
- Scale, Performance and Latency
- Lightweight and Simple
- Easily Extendable
- Distributed Control Plane

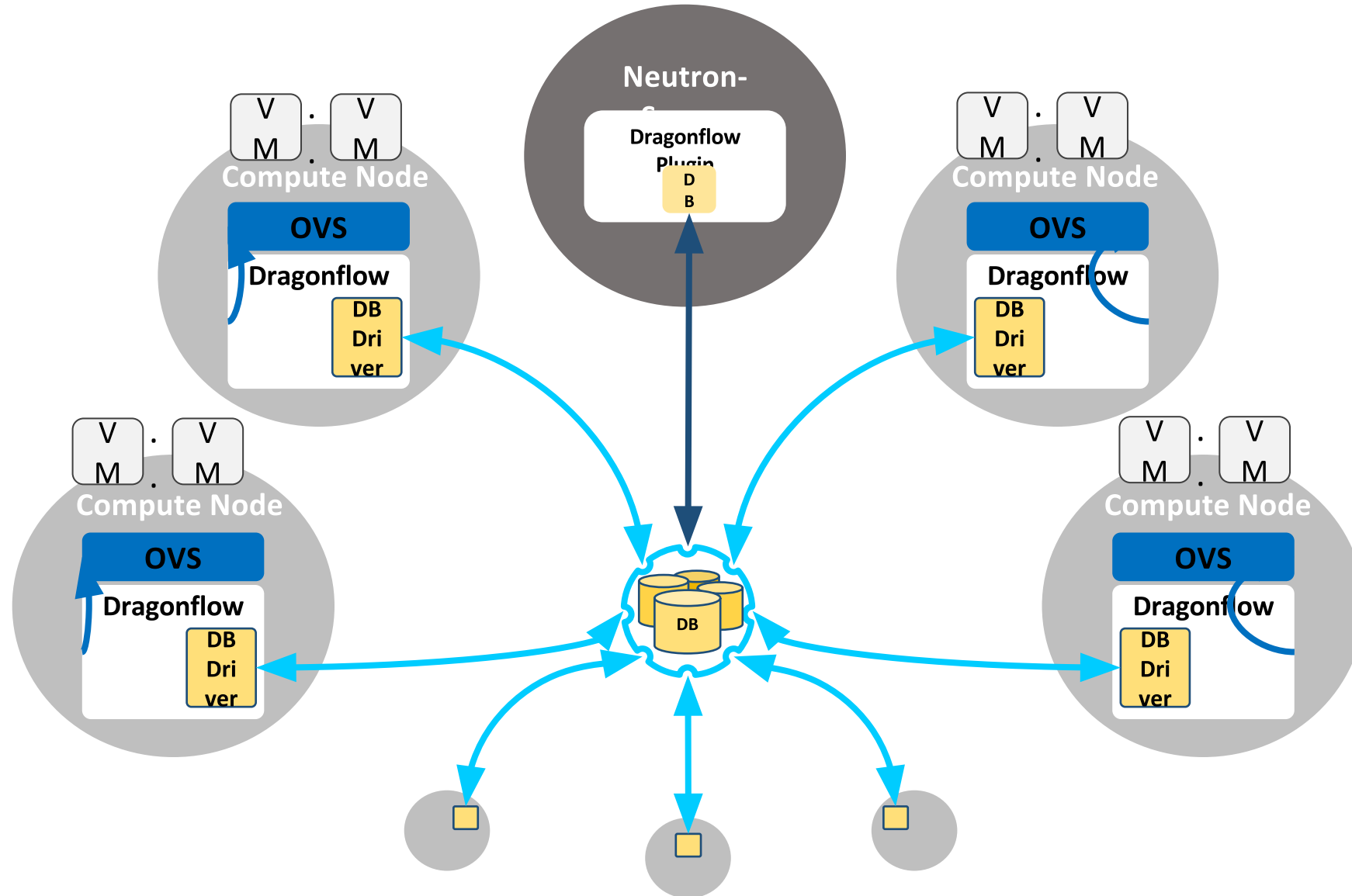

DragonFlow - Distributed SDN



DragonFlow Under the Hood

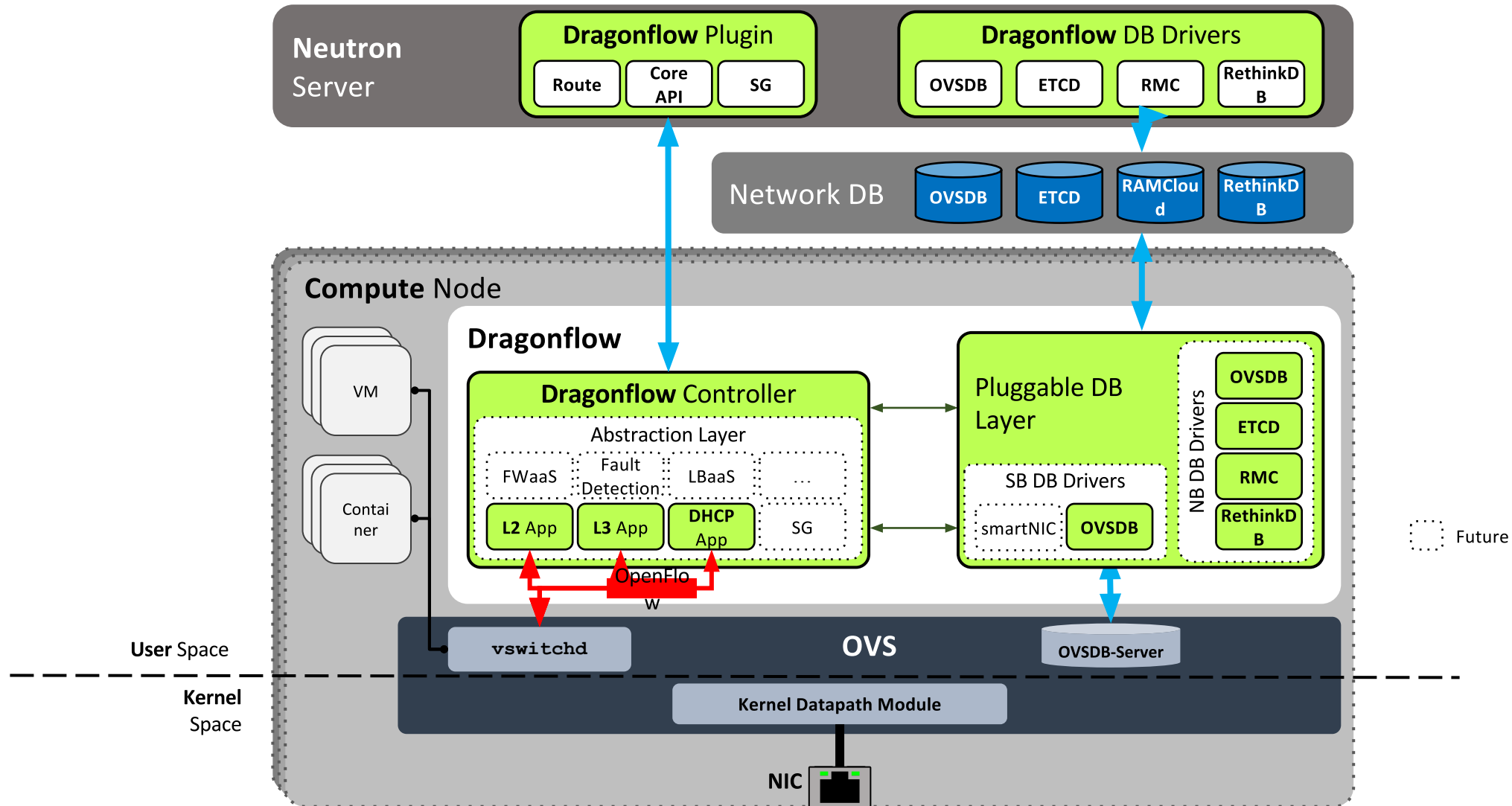

Selective Distribution

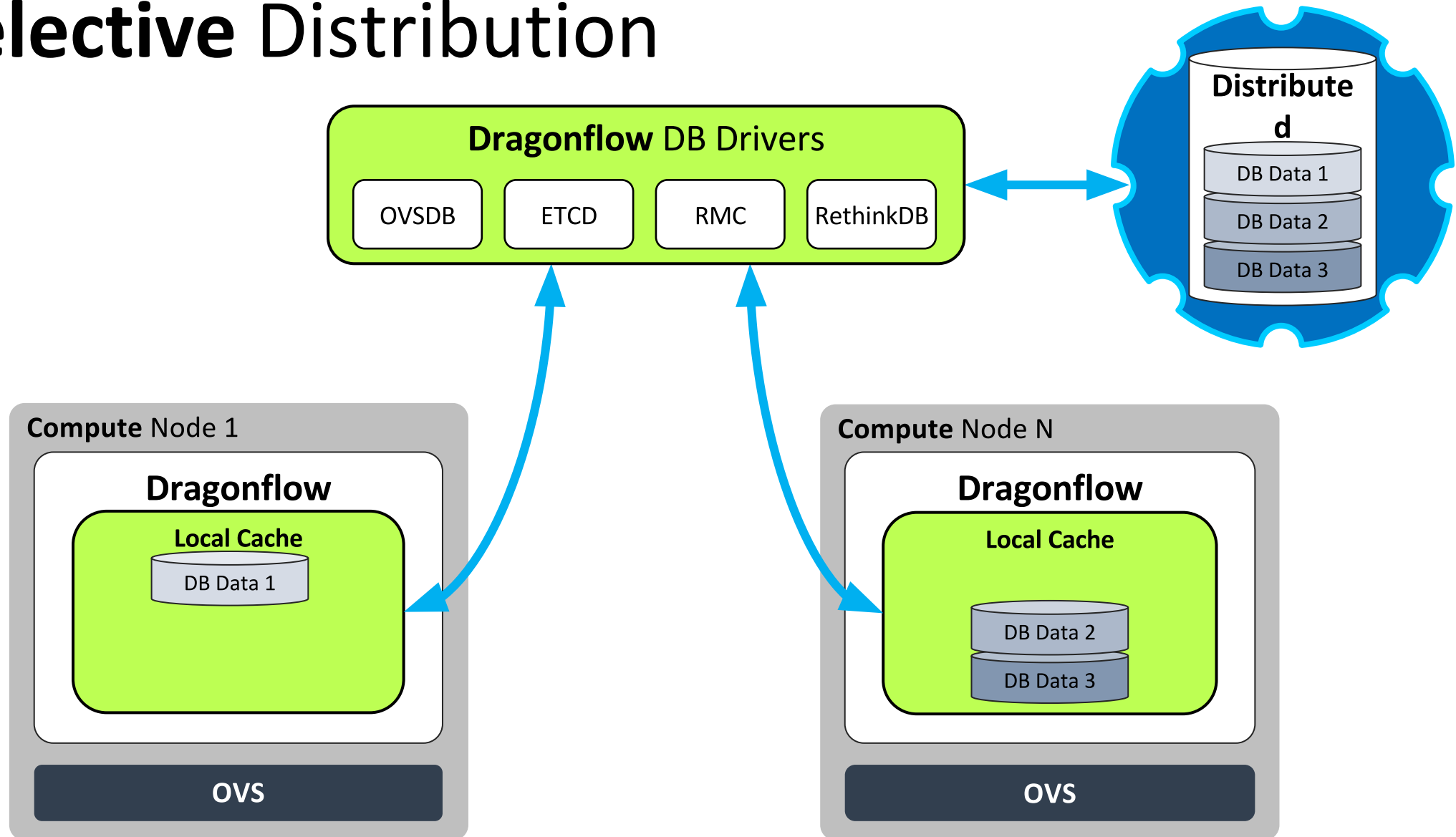

Roadmap

- **Containers**
- **Distributed SNAT/DNAT**
- **Reactive DB**
- **Topology Service Injection / Service Chaining**
- **Smart NICs**
- **Hierarchical Port Binding (SDN ToR)**
- **Inter Cloud Connectivity (Boarder Gateway / L2GW)**
- **Fault Detection**



Thanks!

